



Société Nationale de
Certification et d'Homologation
Société à responsabilité limitée





















October 14th, 2011

STATEMENT

We confirm, that the following replacement silencer type 5512, produced by SITO Gruppo Industriale S.p.A. (S.G.I.), is complying with

- the EC-Directive 97/24/EC Chapter 9 regarding permissible sound level and exhaust system

An EC type approval number has been granted by the luxembourgian Ministry for Sustainable Development and Infrastructure, department of Transport, for the following version of the above mentioned replacement silencer type:

Silencer Version	Drawing No.	Type approval number	Vehicle type	Vehicle Model
4135	4135	SGI  0497 	S60010 – S6	KYMCO YUP 50
4135	4135	SGI  0497 	S80010 – S8	KYMCO BET&WIN 50
4135	4135	SGI  0497 	S80010 – S8	KYMCO DINK 50
4135	4135	SGI  0497 	BA10AD – B1 – (RFB)B10000 – (RFB)B10010 - B1 Vers.02	KYMCO PEOPLE 50 ECO KAT
4135	4135	SGI  0497 	KFJ0AA	KYMCO SUPER 8 50 2t
4135	4135	SGI  0497 	SH10DM – S1	KYMCO SUPER 9 50 2t
4135	4135	SGI  0497 	SF10AG - SF10GG - SF	KYMCO TOP BOY ON/OFF 50
4135	4135	SGI  0497 	SF10FA – U31000 – U3	KYMCO VITALITY 50
4135	4135	SGI  0497 	RFGBL05 – BL05 – BL05W6-6	SYM EUROJET 50
4135	4135	SGI  0497 	CK50QT-6A	KYMCO AGILITY 50.R16



Gilles AST
Expert Technique

Adresse:
BP 23
L-5201 Sandweiler

Siège social:
11, route de Luxembourg
L-5230 Sandweiler

Capital social: 3.500.000 €
R.C. B 27180
N° TVA: LU 13770825

Tél.: (+352) 35 72 14 - 250
Fax: (+352) 35 72 14 - 244
E-mail: info@snch.lu
Home page: www.snch.lu



9932900

Solo per - only for - Seulement pour - Nur für - Sólo para:
KYMC O YUP 50

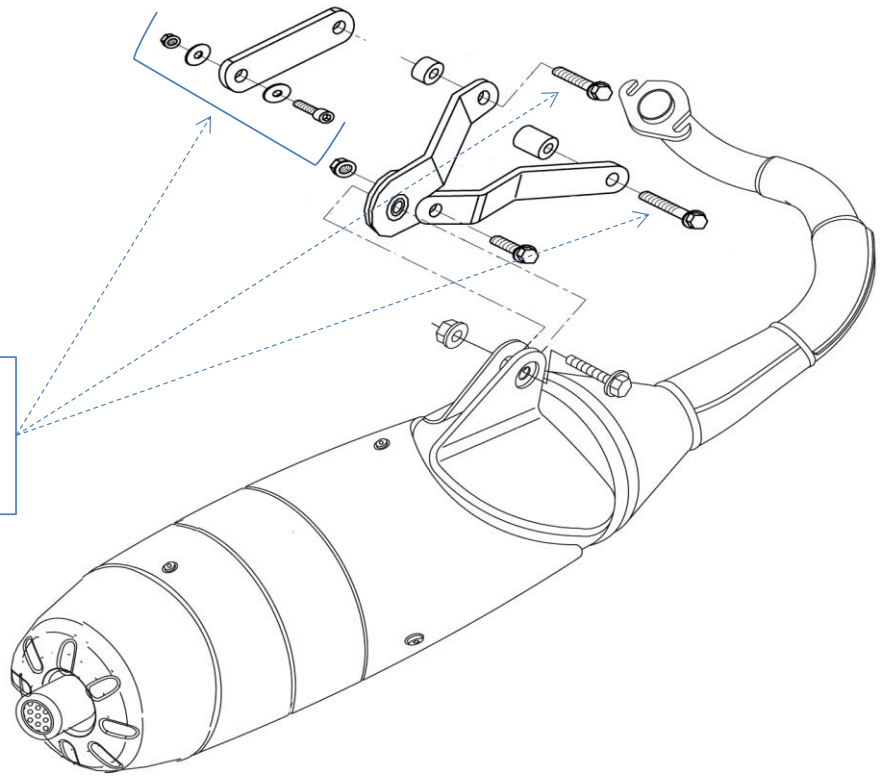

RULLI E MOLLE - ROLLERS AND SPRINGS - MASSELOTTES ET RESSORTS - ROLLEN UND FEDERN - RODILLOS Y MUELLES

- RULLI:** Solo per KYMCO TOP BOY 50 ON/OFF - SUPER 8 50: Art. 4646 gr. 5,7
- ROLLERS:** Only for KYMCO TOP BOY 50 ON/OFF - SUPER 8 50: Art. 4646 gr. 5,7
- MASSELOTTES:** Soulement pour KYMCO TOP BOY 50 ON/OFF - SUPER 8 50: Art. 4646 gr. 5,7
- RODILLOS:** Para KYMCO TOP BOY 50 ON/OFF - SUPER 8 50: Art. 4646 gr. 5,7
- ROLLEN:** Für KYMCO TOP BOY 50 ON/OFF - SUPER 8 50: Art. 4646 gr. 5,7

**DISEGNO TECNICO RULLI E MOLLE - TECHNICAL DRAWING ROLLERS AND SPRINGS
CROQUIS TECHNIQUE MASSELOTTES ET RESSORTS - TECHNISCHE ZEICHNUNG ROLLEN UND FEDERN
DISEÑO TÉCNICO RODILLOS Y MUELLES**

FIGURA 1



FIGURA 2



MOLLE DA SOSTITUIRE - SPRINGS TO BE REPLACED
RESSORTS À REMPLACER - ZU ERSETZENDE FEDER
MUELLES PARA SUSTITUCIÓN

FIGURA 3

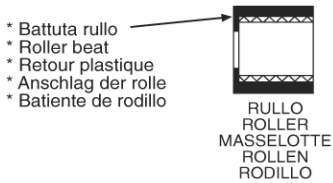
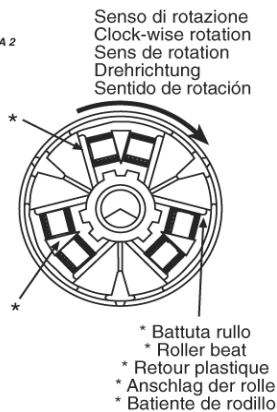
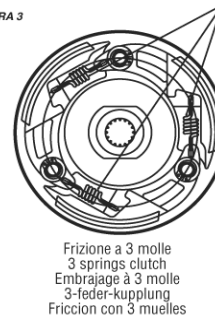

FIGURA 4

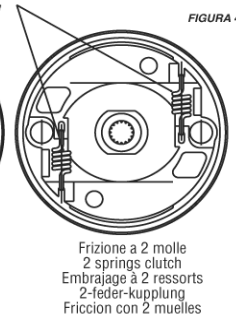

VISTA DAL LATO INTERNO - VIEW FROM THE INNER SIDE
VUE DE L'INTÉRIEUR - ANSICHT VON INNENSEITE
VISTA DESDE EL LADO INTERIOR